

3900 Series

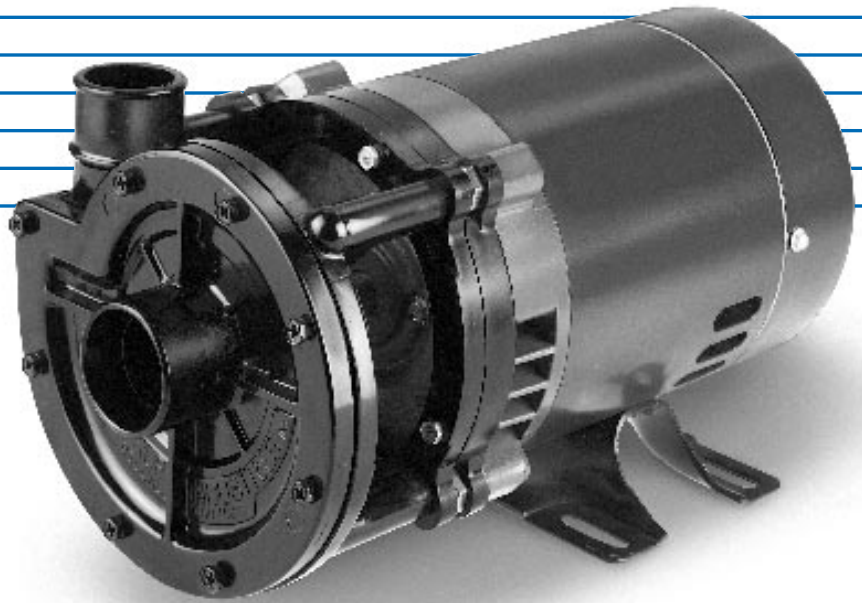

Pump Specifications:

Flow Rates — Range to 60 gpm;
maximum head
34 feet

Motor — 115/230V, 50/60 Hz
1/3 hp, open, drip-proof,
capacitor start

Fluid Temperature — To 220°F (104°C)

Materials in Contact with Solution:

Body — Phenolic
Impeller — Phenolic
Seal — Carbon and
Ceramic faces
with 302 Stainless
Steel and
EPT/EPDM
elastomers

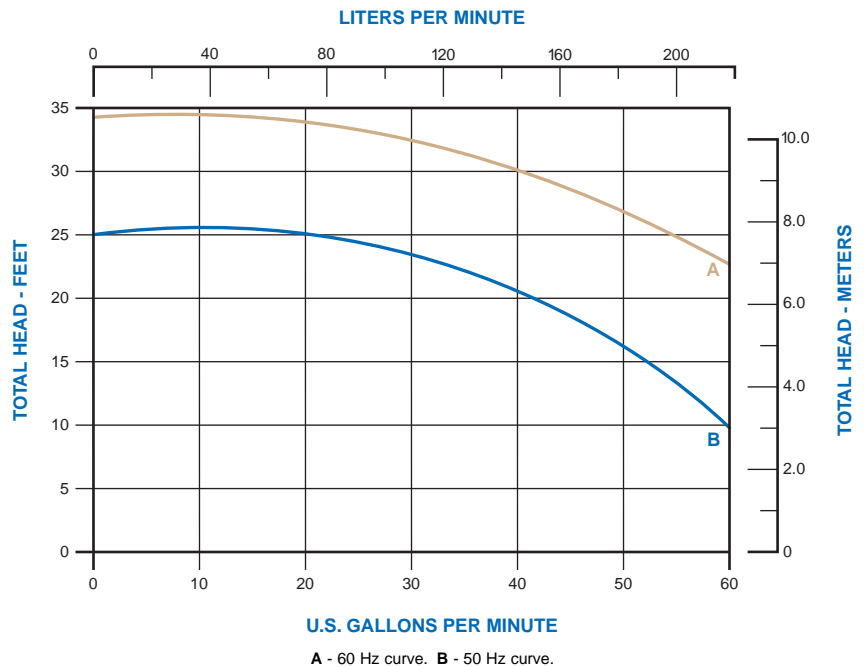

TOTAL HEAD - FEET

TOTAL HEAD - METERS

U.S. GALLONS PER MINUTE

A - 60 Hz curve. B - 50 Hz curve.

MODEL SPECIFICATIONS

Model Number	Series	Seal	Volts	Hz	Amps	Motor Type	Shell	Typical Curve		Approx. Wt.
								50 Hz	60 Hz	
11908-009	3900	Mech	115/230	60	7.6/3.8	Cap. Start	Open D.P.	B	A	15.6 lbs.
			115/230	50	8.2/4.1					

CENTRIFUGAL PUMPS - TYPICAL DIMENSIONS

3900 Series Model

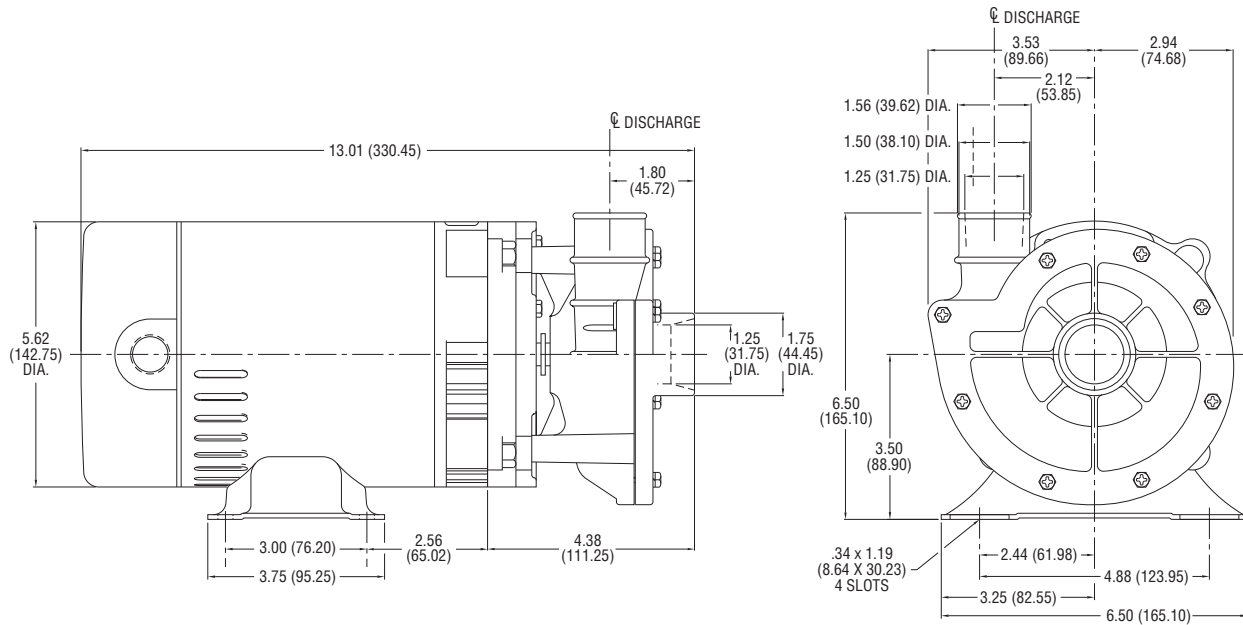

Dimensions in Inches
(Dimensions in Millimeters)

OEM Options

Impellers — Two different diameter Phenolic impellers are available to provide greater performance ranges

- a. Phenolic with 316 Stainless Steel impeller shaft
- b. Phenolic with Brass impeller shaft

Motor — Pedestal (no motor)

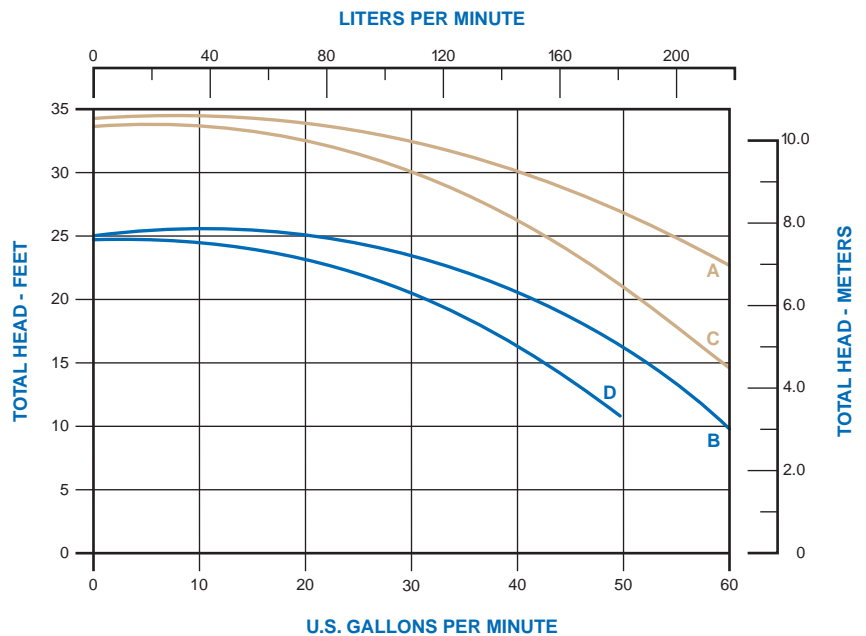

Curves A and B are with large impeller. A and C - 60 Hz curves. B and D - 50 Hz curves.